

The headset parts may be cleaned with mild soap and water using a soft cloth. Then dry immediately. **Caution: Do Not immerse** any part of the headset in water or any other liquid. Be especially careful not to allow the microphone to become wet! Exposure to moisture may cause internal corrosion and failure and will void your manufacturers warranty.

Cleaning will help the headset maintain its "like new" condition for many years.

### WINDSCREEN

The microphone windscreen will reduce annoying wind noise and breath pops picked up by headset microphones. It also protects the microphone element from dirt and moisture. The windscreen should be washed regularly to maintain hygiene and avoid clogging. Wash in warm water and mild soap. Rinse thoroughly and make sure it is completely dry before putting it back on.

To remove the windscreen, carefully grasp the windscreen lightly along its entire length and remove from the microphone element being careful not to twist the element itself.

Put the windscreen on the microphone by gently pulling from the open end. Do not pull it so tightly that it stretches against the end of the microphone.

### WARRANTY

Your headset is covered by a limited one-year parts and labor warranty. Please see the enclosed warranty card for details.

You may refer to the parts list on the reverse side, if you choose to replace parts yourself. The parts list describes parts for this particular headset only. Parts lists for other models are available on our Web Site or can be obtained by contacting Sigtronics Corporation.



Sigtronics Corporation  
178 East Arrow Highway  
San Dimas, CA 91773  
**Phone:** 909 305-9399  
**E-mail:** info@sigtronics.com  
**Web Site:** www.sigtronics.com

# Model SE-18RPTT Headset Instructions

The SE-18RPTT series headset is adjusted at the factory for immediate use. The headset is equipped with a single plug and a coiled cord.

The headband is adjustable through a full range of motion, and the locking nuts may be tightened to allow you to custom fit the headphone. Place the headphone over your head and adjust the slides up until minimum pressure is felt on the top of your head. For maximum noise attenuation, the clamping pressure of the headband has been set at the factory. Releasing the clamping pressure by bending the headband is **not advised**, because loss of attenuation will result.

The microphone boom is fully adjustable and will rotate 180 degrees for use on the left or right side of the head.

**Make sure you are speaking into the side of the mic labeled "Talk" or substantial loss of gain will occur. Microphone placement should be at the corner of the mouth, approximately 1/4" from the lips.**

Your SE-18RPTT headset has a push to transmit switch located on the mic side ear cup. When the headset is connected to a radio, depressing this switch will cause the radio to transmit. The switch is **not used** for intercom function.

When you **first connect the headset**, turn the volume control on the headset up to the full clockwise position, then adjust the listening volume with the audio control of either your radio or intercom as appropriate. If applicable, crew members should also turn their individual headset volumes up fully. Doing this allows for a full range of adjustment for each passenger, since those with the most acute hearing can turn their headset volume down, if necessary.

continued on back...



**...when it counts!**

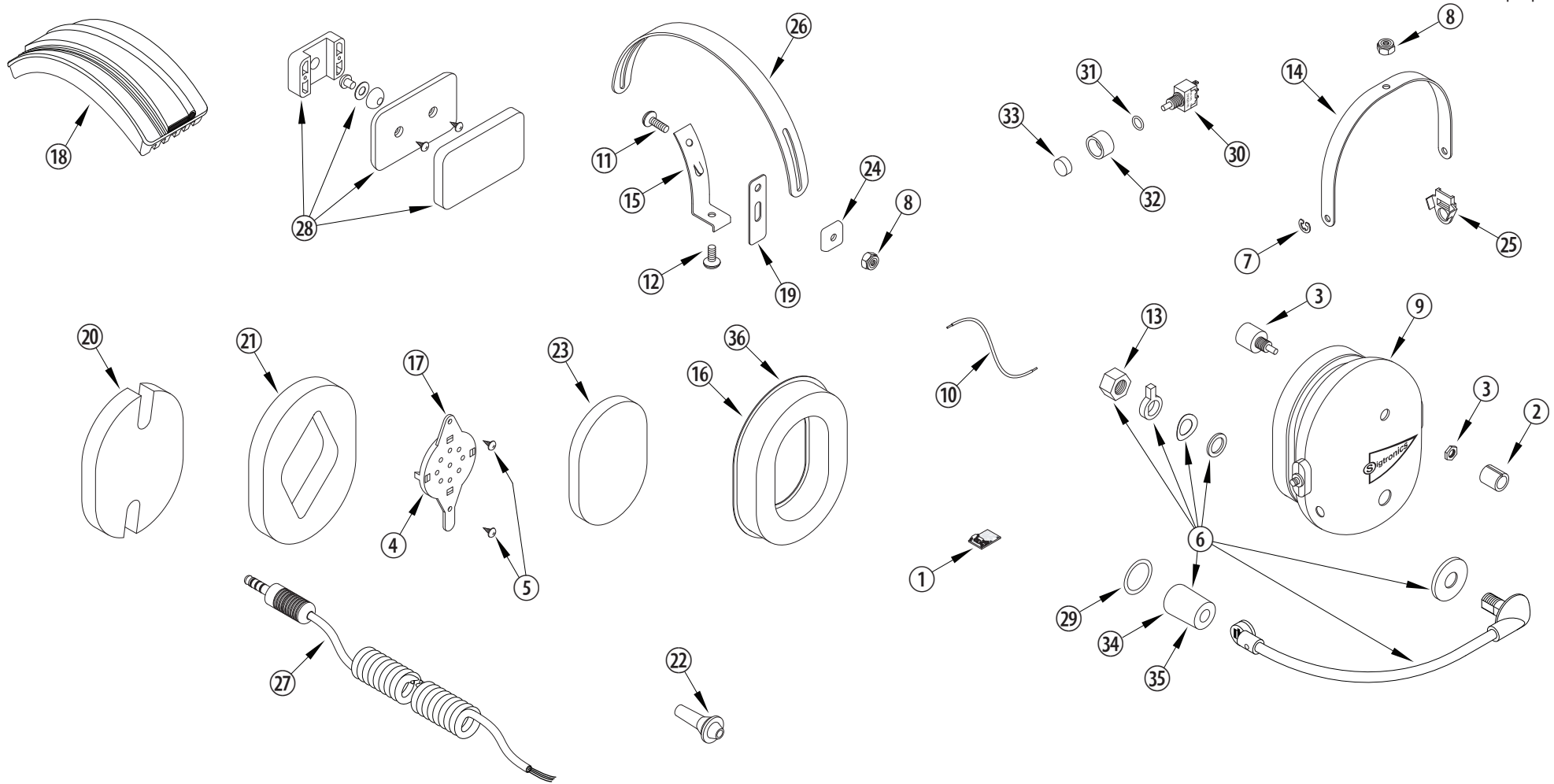

### SIGTRONICS SE-18RPTT HEADSET PARTS IDENTIFICATION BREAKDOWN

ITEM	P/N	DESCRIPTION	ITEM	P/N	DESCRIPTION	ITEM	P/N	DESCRIPTION
1	800192	PREAMP	13	100597	NUT, HEX, 3/8-24, FLEX BOOM ADAPTER	25	100393	CLIP, ANTI-ROTATION, YOKE, PLASTIC
2	100063	KNOB, 3/8 INCH, BLACK, VOLUME	14	100603	YOKE, EAR CUP MOUNT, METAL, BLACK	26	100613	HEADBAND, METAL, LARGE, BLACK
3	100077	POTENTIOMETER	15	100604	BRACKET, YOKE SUPPORT WITH TANG, BLACK	27	800046	CABLE, HEADSET, COILED
4	100079	RECEIVER, 300 OHM, MONO	16	100369	EAR SEAL, FOAM FILLED	28	800118	HEADPAD ASSEMBLY, SIDE, WITH CUSHION, SE-18
5	100108	SCREW, 4-40 X 1/4, THREAD FORMING	17	100370	RECEIVER MOUNT, HEADSET	29	100612	O-RING, WINDSCREEN RETAINER, SE-18
6	800193	MICROPHONE & FLEX BOOM ASSEMBLY	18	800198	HEADPAD WITH CUSHION, TOP, SE-18	30	100232	SWITCH, SPDT, MOMENTARY
7	100251	E-RING, EAR CUP TO YOKE RETAINER	19	100373	SLIDE, YOKE BRACKET, LONG, NYLON	31	100625	O-RING, PTT, HEADSET
8	100252	NUT, HEX, 8-32, LOCKING	20	100374	FOAM, SOUND ATTENUATING. NOTCHED, 1/2 INCH	32	100428	SWITCHGUARD, PTT, BLACK
9	100361	EAR CUP, PRINTED AND DRILLED	21	100376	FOAM, SOUND ATTENUATING. RECEIVER HOLE, 1/2 INCH	33	100317	BUTTON, SWITCH, PTT, RED
10	100221	WIRE, #22, 19 STRAND, 4 INCH	22	100569	STRAIN RELIEF, CABLE	34	900111	WINDSCREEN, MICROPHONE, FOAM, PACKAGED
11	100363	SCREW, 8-32 X 1/2, PHILLIPS HEAD	23	100379	FOAM, SOUND ATTENUATING, RECEIVER COVER, 1/4 INCH	35	100611	WINDSCREEN, MICROPHONE, FOAM, BULK
12	100364	SCREW, 8-32 X 3/8, PHILLIPS HEAD	24	100258	CLIP, HEADBAND GUIDE, PLASTIC	36	100402	OPTIONAL - EAR SEAL, GEL FILLED