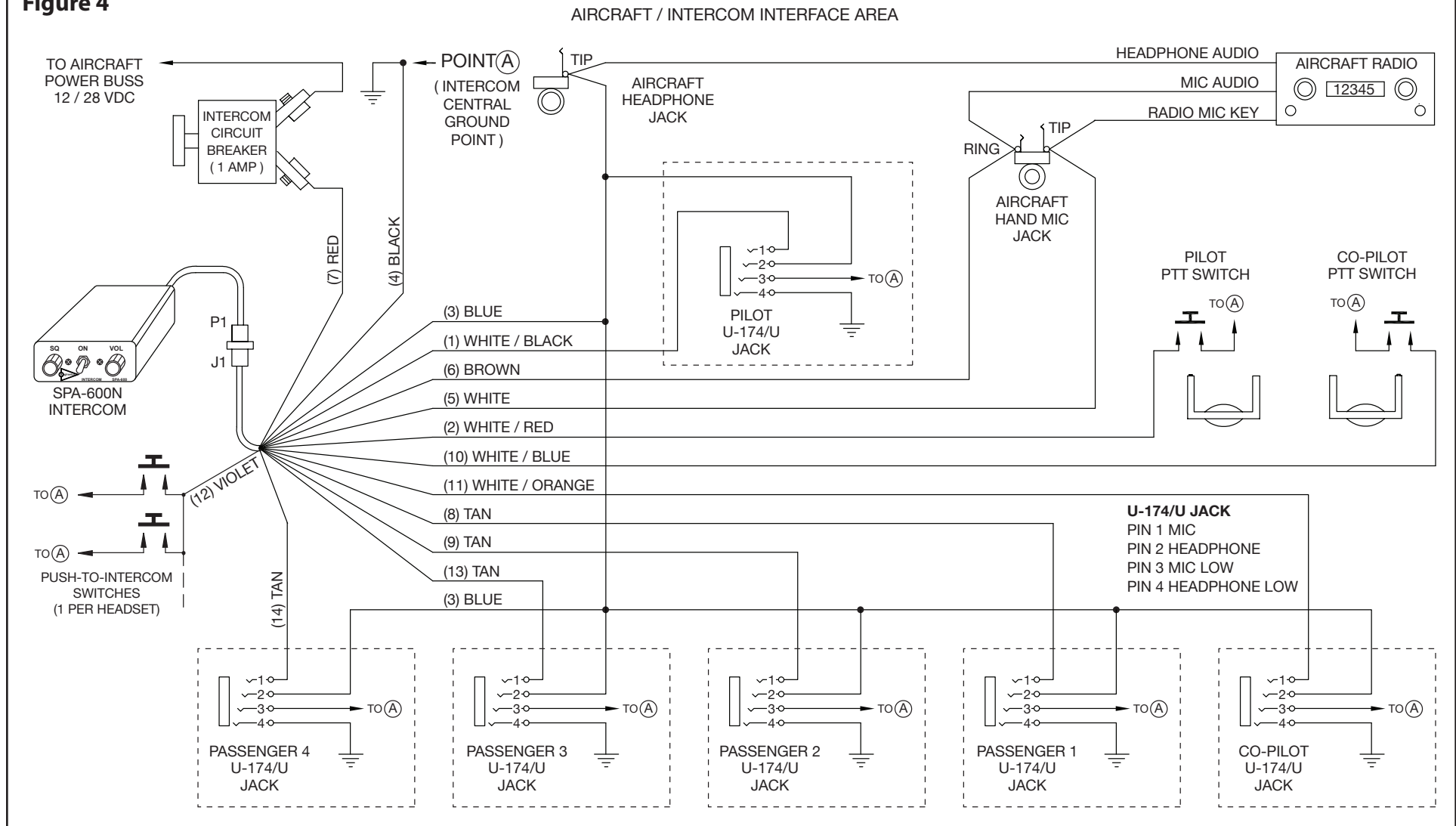

Figure 4



SPA-600N With U-174/U Jacks Installation Wiring Diagram

NOTES

1. IF PILOT PTT SWITCH IS CONNECTED TO THE AIRCRAFT HAND MIC JACK, IT MUST BE DISCONNECTED AND CONNECTED TO THE WHITE / RED WIRE AS SHOWN.
2. AIRCRAFT CHASSIS GROUND.
3. SEE RADIO MANUFACTURERS INSTALLATION INSTRUCTIONS FOR ALL POWER, GROUND, AND ANY ADDITIONAL HOOKUPS.
4. THIS INSTALLATION DIAGRAM IS FOR A SINGLE RADIO SYSTEM WITHOUT AUDIO PANEL.

