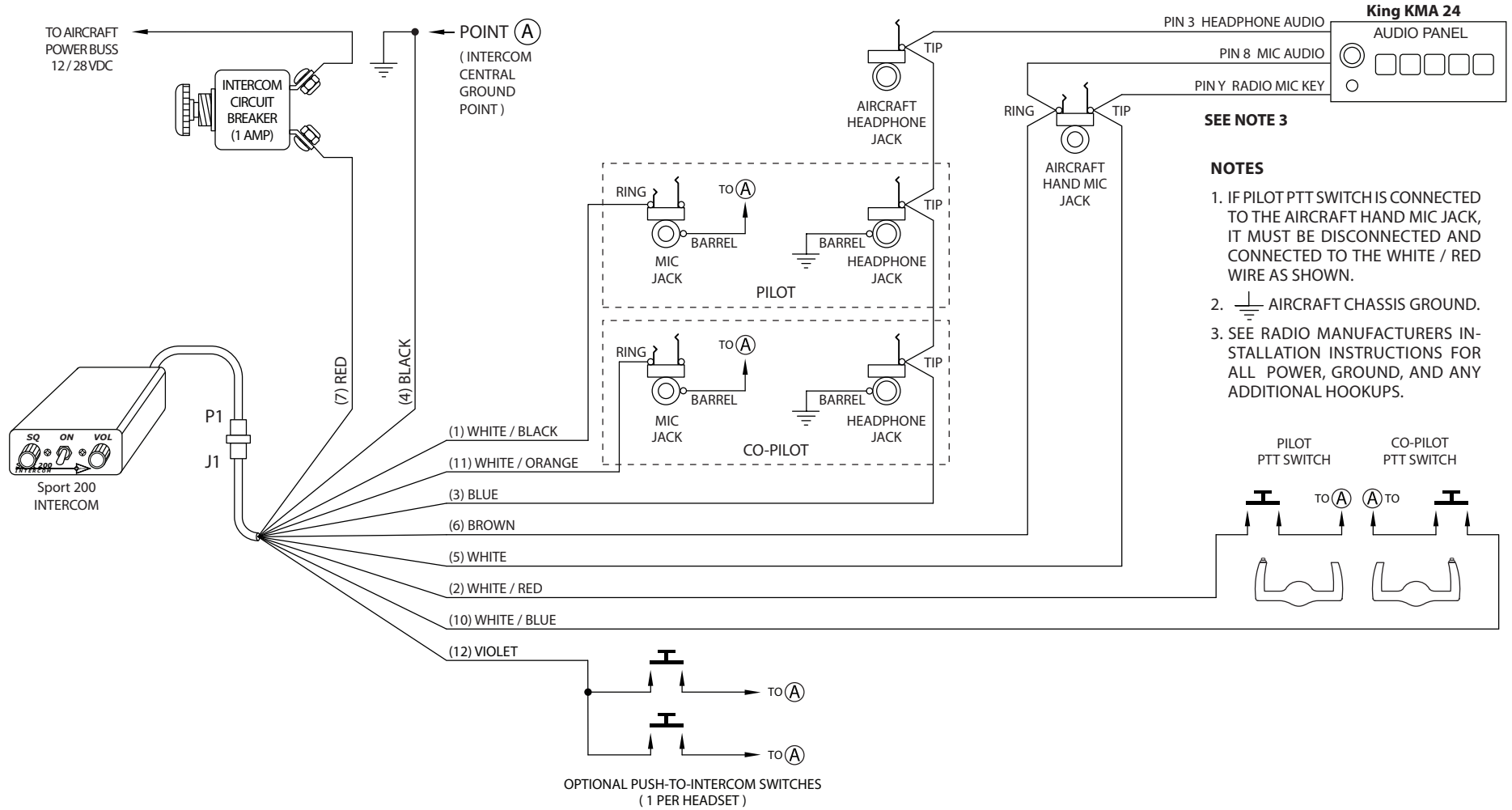

**Figure 4**

AIRCRAFT / INTERCOM INTERFACE AREA



**Sport 200 – King KMA 24 Audio Panel Installation Wiring Diagram**