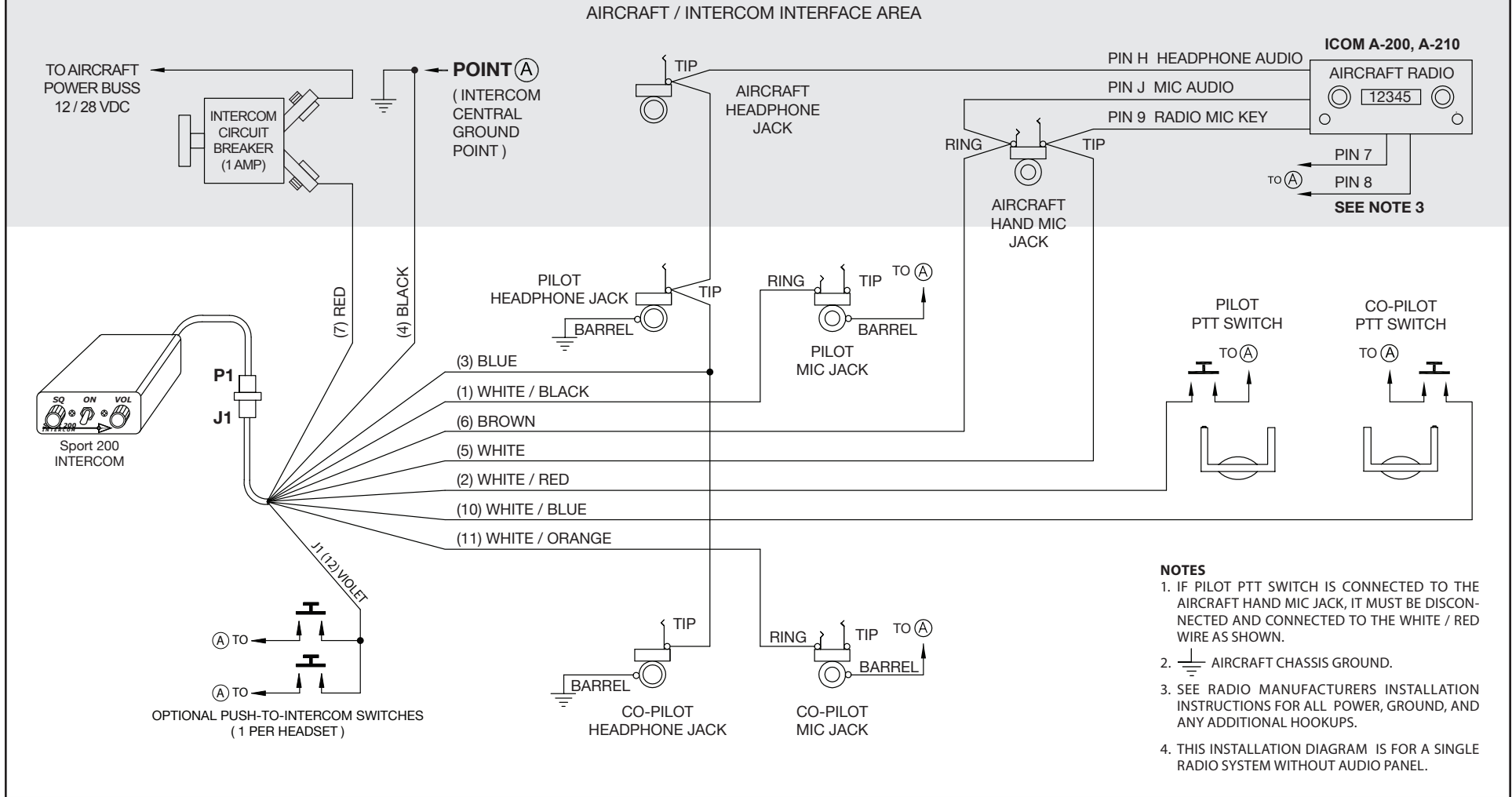

Figure 4



Sport 200 – ICOM A-200, A-210 Radio Installation Wiring Diagram